

ROSS Laboratory High Shear Mixer Model 100LH Specifications and Dimensions

STANDARD FEATURES:

- Table or bench top mount design.
- Driven by an explosion proof (Class 1, Group D), 230/460 V, 3 Ph, 60 Hz, 10:1 speed range, inverter duty motor.
- Low maintenance V-belt drive system.
- Mixing head hydraulically raised by an air/oil hydraulic lift.
- Stainless steel type 316 wetted parts.
- Explosion proof safety limit switches to prevent operation of mixer while in the raised position or without mix vessel in place.
- Adjustable stainless steel can lock to secure mixing vessel.
- Non-stainless steel external parts coated with a two-part acrylic urethane enamel coating.

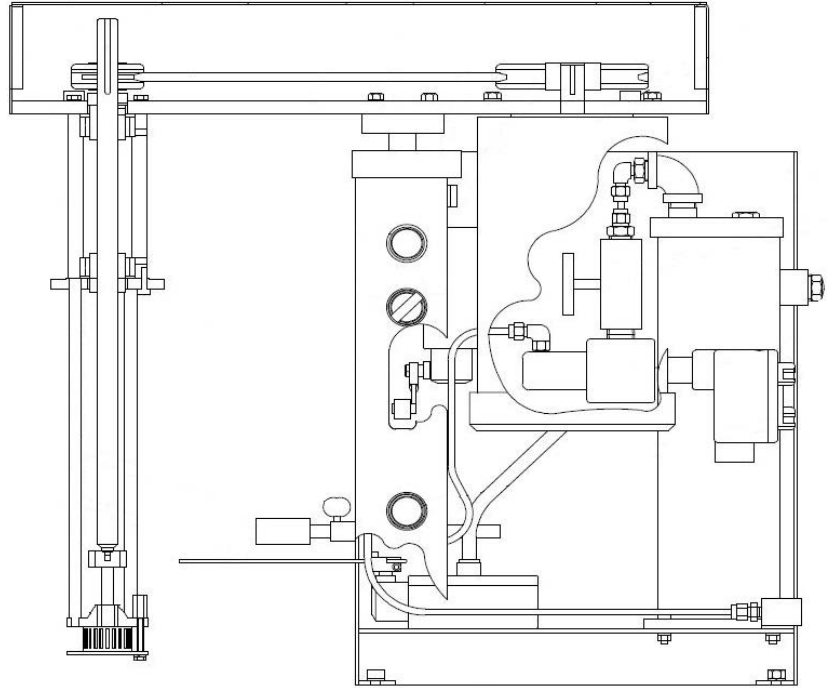

AVAILABLE OPTIONS:

- Down-thrust propeller for standard rotor-stator attachment.
- Variety of rotor shaft bushing materials.
- Variable frequency drive.
- Explosion proof operator station.
- Painted steel or stainless steel bench including lower shelf and leveling mounts. Caster wheels are also available in lieu of leveling mounts.
- Vacuum or atmospheric cover attached to mixer bonnet. Vacuum cover must be ordered with matching mix vessel.

AVAILABLE MIXING ATTACHMENTS:

- HSM Attachment: High Shear Rotor/Stator complete with disintegrating, slotted and fine screen stator heads. Attachment is equipped with a TEFLON® bushing.
- SLIM System: Solids/Liquid Injection Manifold, available only on the 2 HP (HSM-100LH-2) model with HSM Attachment.
- Inline HSM Attachment: Inline High Shear Rotor/Stator complete with disintegrating, slotted and fine screen stator heads.
- HSD Attachment: High Speed Disperser.

Model	HP	Speed RPM	Overall Raised Height		Overall Lowered Height		Overall Width		Overall Length		Water Capacity		Weight	
			in	mm	in	mm	in	mm	in	mm	gal	L	lbs	kg
HSM-100LH-1	1	10,000	41.75	1061	26.75	680	16	407	29	737	0.3 - 4	1.1 - 15	300	136
HSM-100LH-2	2	6,900	41.75	1061	26.75	680	16	407	29	737	1 - 5	3.8 - 19	300	136



Charles Ross & Son Company

710 Old Willets Path
Hauppauge, NY 11788
USA

631-234-0500 / 800-243-ROSS(7677)
sales@mixers.com
mixers.com

Model HSM-100LH Attachments

High Shear Mixer (HSM)

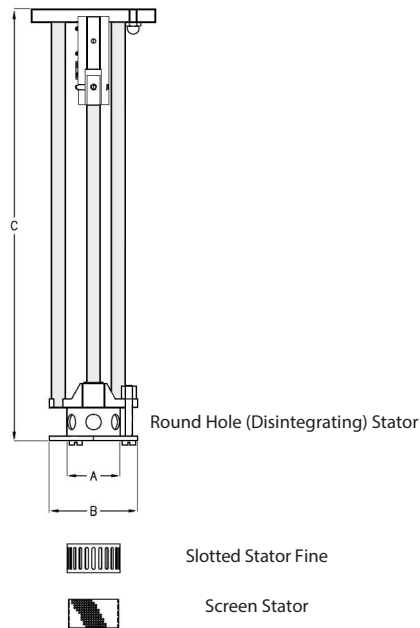

High Speed Disperser (HSD)

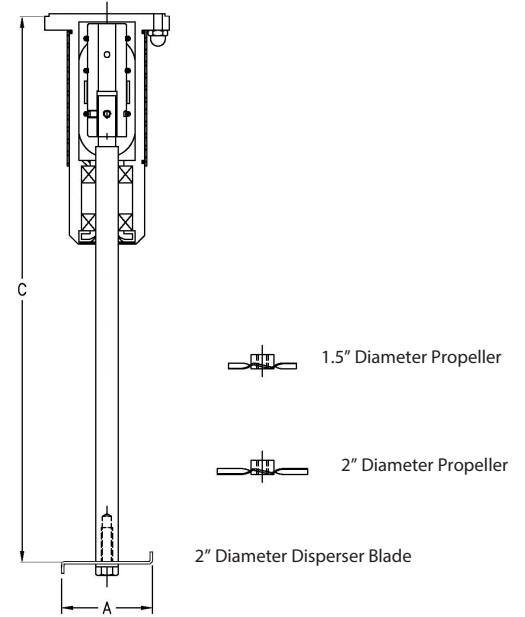

SLIM HSM Attachment

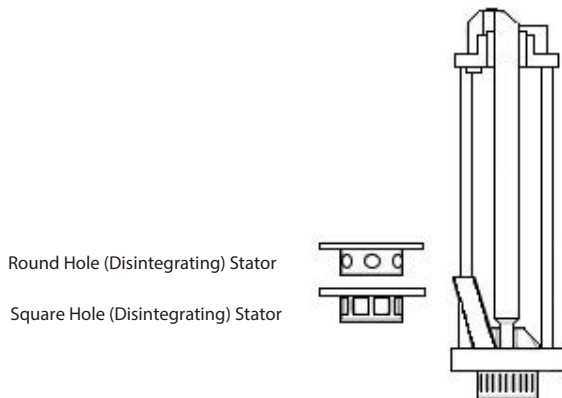

Inline High Shear Mixer (HSM)

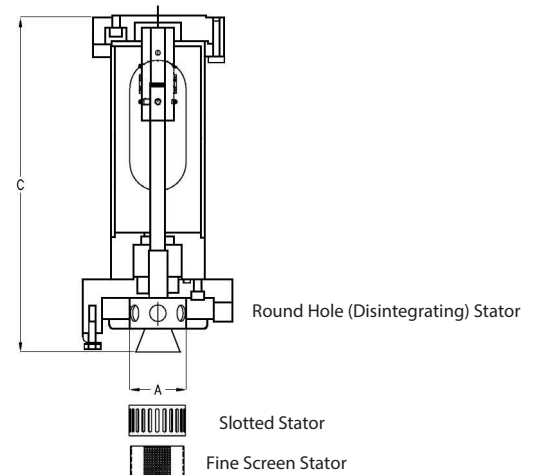

Attachment	Model	Rotor Diameter		Assembly Length	
		in	mm	in	mm
HSM	HSM-100LH-1	1.4	34.9	12.3	313
	HSM-100LH-2	2	51	14.5	369
HSM with SLIM	HSM-100LH-1	N/A	N/A	N/A	N/A
	HSM-100LH-2	2	51	14.9	379
Inline HSM	HSM-100LH-1	1.4	34.9	11.7	298
	HSM-100LH-2	2	51	12.3	313
HSD	HSM-100LH-1	2	51	11.8	300
	HSM-100LH-2	3.5	89	13.8	351



Charles Ross & Son Company

710 Old Willets Path
Hauppauge, NY 11788
USA

631-234-0500 / 800-243-ROSS(7677)
sales@mixers.com
mixers.com