

Laboratory PowerMix (PDM) Specifications and Dimensions

STANDARD FEATURES:

- Full vacuum change can design
- Air/oil hydraulic lift with two-hand operation air-powered controls for raising and lowering the mix can to and from the mixing position (80 - 100 psig air supply required)
- Integrated base design for mounting on table top or work bench
- Rectangular Stirrer and High Speed Dispenser
- Agitator drive components and lift system are fully sheathed
- Stainless steel type 304 wetted parts with 80 grit polish
- Non-stainless steel components are finished with a durable two-part epoxy coating
- TEFC motors designed for 230/460V, 3ph, 50/60Hz
- Stainless steel type 304 gearbox with Viton sealing O-rings and lip seals on stirrer shafts
- Safety limit switch prevents operation of the mixer when the mix vessel is removed or not in the mixing position
- Vacuum hood is easily removed providing access to upper gearbox area for simple maintenance and cleaning

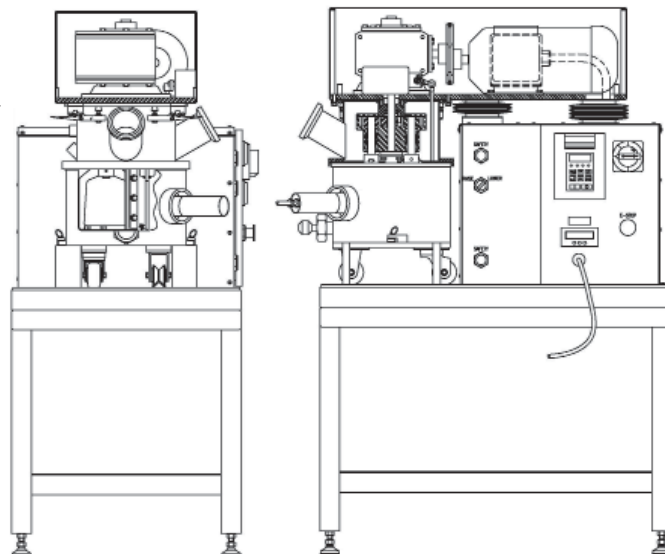

AVAILABLE OPTIONS:

- Wetted parts of stainless steel type 316, Hastelloy or other special alloys
- Sanitary design with special seals, polishes, connections and stainless steel mixer sheathing
- Various agitators offered such as High Viscosity (“HV”) Stirrer, finger type blade, auger, flight bars, chopper blade and other custom design agitators
- Sidewall and bottom scrapers with replaceable blades
- Internal pressure capability
- Explosion-proof motors, special voltages and frequencies
- Sight/charge ports, inlet/outlet nozzles and flush tank discharge valves
- Temperature probes, pressure transducers and other batch sensors
- Jacketed mix vessel for heating and/or cooling
- Internally-machined mix vessel for use with a Ross Discharge System
- Carbon or stainless steel mixer bench. Common bench option for mounting of mixer and Discharge System
- Variable frequency drives, explosion-proof operator stations and PLC recipe controls
- Vacuum pump, heater, chiller and other auxiliary equipment

Model	Mixing Capacity Gallons	Planetary Stirrer			High Speed Dispenser		Overall Height in	Overall Width in	Overall Length in	Mix Vessel Overall Height in	Mix Vessel Inner Diameter in	Mix Vessel Depth in	Weight lbs
		HP	Orbital RPM	Stirrer RPM	HP	Stirrer RPM							
PDM-1Qt	0.125 - 0.25	1/2	N/A	35 - 320	1/2	600 - 6,000	38	18	30	5	5.88	4	900
PDM-1/2	0.17 - 0.5	1/2	18 - 175	25 - 254	1	600 - 6,000	38	33	36	6.63	5.5	5.5	1,000
PDM-1	0.5 - 1	1	7 - 72	11 - 112	1	700 - 7,000	41	33	36	6.5	8.25	5	1,100
PDM-2	0.78 - 1.5	1	7 - 72	11 - 112	1.5	500 - 5,000	41	33	36	8	9.63	6.5	1,200
PDM-4	2.25 - 4	1.5	7 - 70	10 - 101	2	450 - 4,500	45	33	36	9.63	14	8	1,400
PDM-5	2.25 - 5	1.5	7 - 70	10 - 101	2	450 - 4,500	45	33	36	11.63	14	10	1,400



CHARLES ROSS & SON COMPANY

P.O. Box 12308, 710 Old Willets Path, Hauppauge, NY 11788

Phone: 631-234-0500 • Fax: 631-234-0691

Website: www.mixers.com • E-mail: sales@mixers.com